



World Pulses Day

#LovePulses for healthy diets and planet

Imara Technology Ltd

Speaker: Alfred Chengula

Date: 10/02/2021







How we link with CIAT?

- Training of large Multi Crop Thresher (MCT)
- Testing of small MCT with CIAT and TARI
- Market promotion of MCT

Problem

*thresh (v.)
to separate seed from
the plant*

3 hours
Needed to thresh
90kg of beans
by hand





SOLUTION

3 hours turns into
20 minutes
To thresh 90kg of beans

Huge Impact
On time, labor,
and
productivity for
smallholders

PRODUCT UNIQUENESS

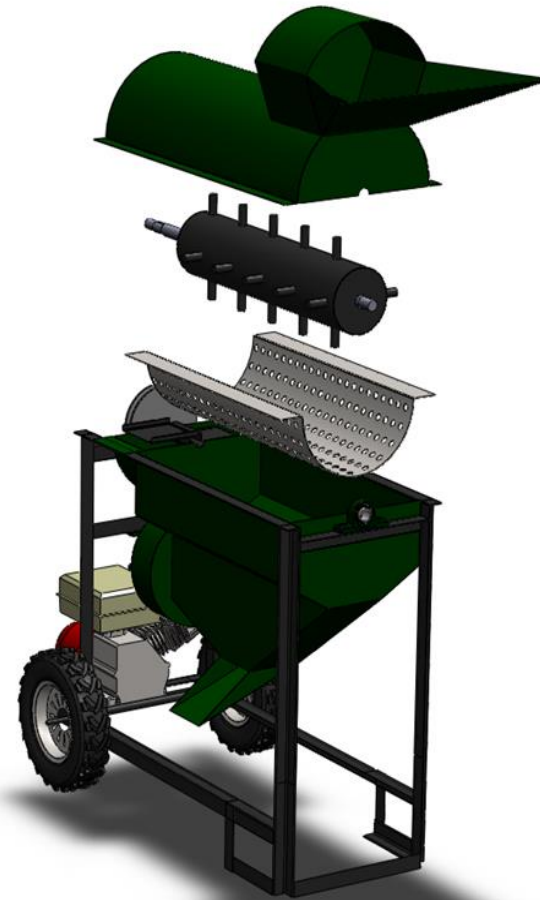

Modular Design: Does
9 Varieties Crops.

Faster: 75x faster than
a Traditional Methods.

Portable: Fit on
Motorcycle

customers

**\$10/hour
net income**



**70 hour
payback**



Business Model

Local & Lean
Manufacturing
to reduce overhead

Sales
Channels
B2C and B2B

Job Creation For Community.

Job Created in 2020

- **Grow up our team to 10 people:** (Permanent Employee with the average age of 28 years)
- **Contracted 20 local technicians.**
- **190 young entrepreneurs bought our thresher for business.**
- **54 thresher bought for farmer groups and NGO's**
- **Impacted over 10,000 farmers.**

Job Creation in 2021

- **Growing up our team to 20 people:** (Permanent Employees with the average age of 28 years)
- **Contracting 40 local technicians.**
- **Estimating 400 young entrepreneurs to buy thresher for business.**
- **Estimating to sell 100 threshers to farmer groups and NGO's**
- **Impact over 25,000 farmers.**

Impact Assessment of Thresher.

- *How the adoption of MCT has impacted the women?*





TEAM

Thank you!

World Pulses Day

#LovePulses for healthy diets and planet

